

Six-channel, Delta-sigma Analog-to-digital Converter

Features

- Synchronous Sampling
- On-chip 1.2 V Reference (25 ppm/°C typ.)
- Power Supply Configurations:
 - VA+ = +3 V; VA- = -2 V; VD+ = +3 V
 - Supply Tolerances: ±10%
- Power Consumption
 - 23 mW Typical at VD+ = +3 V
- Simple Four-wire Serial Interface
- Charge pump driver output generates negative power supply.
- Ground-referenced Bipolar Inputs

Description

The CS5451A is a highly integrated delta-sigma ($\Delta\Sigma$) analog-to-digital converter (ADC) developed for the power measurement industry. The CS5451A combines six $\Delta\Sigma$ ADCs, decimation filters, and a serial interface on a single chip. The CS5451A interfaces directly to a current transformer or shunt to measure current, and to a resistive divider or transformer to measure voltage. The product features a serial interface for communication with a microcontroller or DSP. The product is initialized and fully functional upon reset, and includes a voltage reference.

ORDERING INFORMATION:

See page 13.

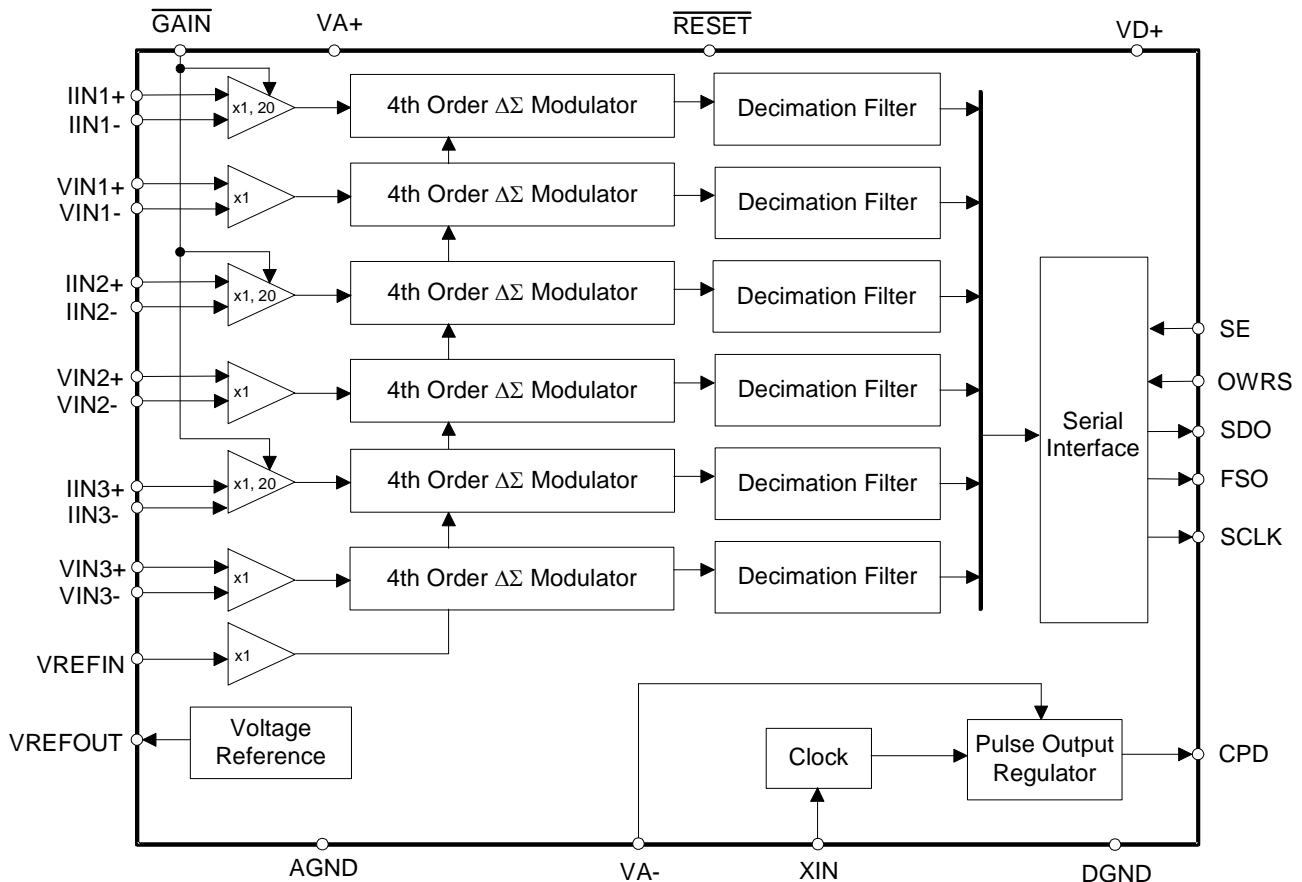

TABLE OF CONTENTS

1. PIN DESCRIPTION	3
2. CHARACTERISTICS AND SPECIFICATIONS	4
3. THEORY OF OPERATION	8
4. FUNCTIONAL DESCRIPTION	9
4.1 Analog Inputs	9
4.2 Digital Filters	9
4.3 Performing Measurements	9
4.4 Serial Interface	9
4.5 System Initialization	10
4.6 Voltage Reference	10
4.7 Power Supply	10
5. PACKAGE DIMENSIONS	12
6. ORDERING INFORMATION	13
7. ENVIRONMENTAL, MANUFACTURING, & HANDLING INFORMATION	13
8. REVISION HISTORY	13

LIST OF FIGURES

Figure 1. Serial Port Timing	6
Figure 2. Typical Connection Diagram	8
Figure 3. One Data Frame	10
Figure 4. Serial Port Data Transfer	10
Figure 5. Generating VA- with a Charge Pump	11

1. PIN DESCRIPTION

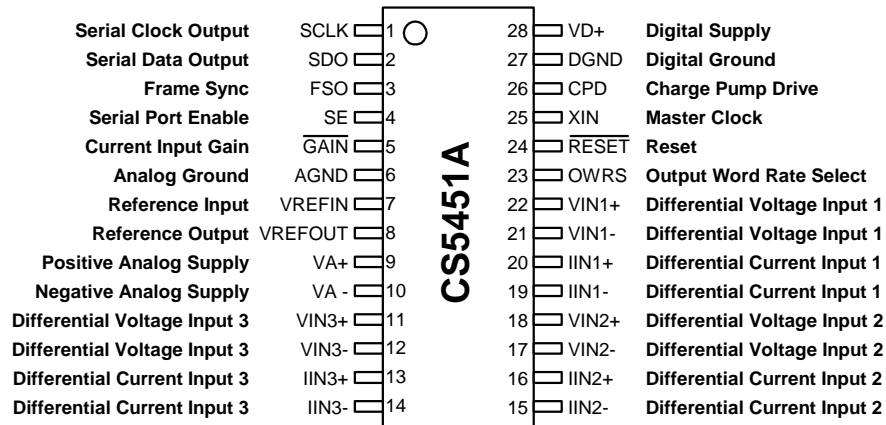

Clock Generator

Master Clock Input	25	XIN - External clock signal or oscillator input.
---------------------------	----	---

Control Pins and Serial Data I/O

Serial Clock Output	1	SCLK - Serial port clock signal that determines the output data rate for SDO pin. Rate of SCLK is dependent on the XIN frequency and state of OWRS pin.
Serial Data Output	2	SDO - Serial port data output pin. Data will be output at a rate defined by SCLK.
Frame Sync	3	FSO - Framing signal indicates when data samples are about to be transmitted on the SDO pin.
Serial Port Enable	4	SE - When SE is low, the output pins of the serial port are tri-stated.
Current Input Gain	5	GAIN - A logic high sets current channel gain to 1, a logic low sets the gain to 20. If no connection is made to this pin, it will default to logic low level (through internal 200 kΩ resistor to DGND).
Output Word Rate Select	23	OWRS - A logic low sets the output word rate (OWR) to XIN/2048 (Hz). A logic high sets the OWR to XIN/1024 (Hz). If no connection is made to this pin, then OWRS will default to logic low level (through internal 200 kΩ resistor to DGND).
Reset	24	RESET - Low activates Reset, all internal registers are set to their default states.

Analog Inputs/Outputs

Voltage Reference Input	7	VREFIN - The input to this pin establishes the voltage reference for the on-chip modulator.
Voltage Reference Output	8	VREFOUT - The on-chip voltage reference output. The voltage reference has a nominal magnitude of 1.2 V and is referenced to the AGND pin on the converter.
Differential Voltage Inputs	11,12 18,17 22,21	VIN3+, VIN3- - Differential analog input pins for the voltage channel 3. VIN2+, VIN2- - Differential analog input pins for the voltage channel 2. VIN1+, VIN1- - Differential analog input pins for the voltage channel 1.
Differential Current Inputs	13,14 16,15 20,19	IIN3+, IIN3- - Differential analog input pins for the current channel 3. IIN2+, IIN2- - Differential analog input pins for the current channel 2. IIN1+, IIN1- - Differential analog input pins for the current channel 1.

Power Supply Connections

Analog Ground	6	AGND - Analog ground.
Positive Analog Supply	9	VA+ - The positive analog supply. Typical +3 V ±10% relative to AGND.
Negative Analog Supply	10	VA- - The negative analog supply. Typical -2 V ±10% relative to AGND.
Charge Pump Drive	26	CPD - Designed to drive external charge pump circuitry that will produce a negative analog supply (VA-) voltage.
Digital Ground	27	DGND - Digital Ground.
Positive Digital Supply	28	VD+ - The positive digital supply. Typical +3 V ±10% relative to AGND.

2. CHARACTERISTICS AND SPECIFICATIONS

RECOMMENDED OPERATING CONDITIONS

Parameter	Symbol	Min	Typ	Max	Unit	
DC Power Supplies	Positive Digital	VD+	2.7	3.0	3.3	V
	Positive Analog	VA+	2.7	3.0	3.3	V
	Negative Analog	VA-	-2.2	-2.0	-1.8	V
Voltage Reference Input	VREF+	-	1.2	-	V	

ANALOG CHARACTERISTICS

- Min/Max characteristics and specifications are guaranteed over all Operating Conditions.
- Typical characteristics and specifications are measured at nominal supply voltages and TA = 25 °C.
- VA+ = VD+ = 3 V ±10%; VA- = -2 V ±10%; AGND = DGND = 0 V; VREFIN = +1.2 V. All voltages with respect to 0 V.
- XIN = 4.096 MHz.

Parameter	Symbol	Min	Typ	Max	Unit	
Accuracy (All Channels)						
Total Harmonic Distortion	THD	74	-	-	dB	
Common Mode Rejection (DC, 50, 60 Hz)	CMRR	80	-	-	dB	
Common Mode + Signal on Input		VA-	-	VA+	V	
Input Sampling Rate		-	XIN/8	-	Hz	
Analog Inputs (Note 1)						
Differential Input Voltage Range [(I_{IN+}) - (I_{IN-})] or [(V_{IN+}) - (V_{IN-})]	Gain=20	VIN	-	80	-	mV _{P-P}
	Gain=1	VIN	-	1.6	-	V _{P-P}
Bipolar Offset	Gain=20	VOS	-	±11.5	±20	mV
	Gain=1	VOS	-	±0.5	±4.0	mV
Crosstalk (Channel-to-channel) (50, 60 Hz)		-	-105	-	dB	
Input Capacitance	Gain = 20	IC	-	-	20	pF
	Gain = 1	IC	-	-	1	pF
Effective Input Impedance	Gain=20	EII	50	60	-	kΩ
	Gain=1	EII	500	600	-	kΩ
Noise (Referred to Input) 0-60 Hz	Gain=20		-	-	1	μV _{rms}
	Gain=1		-	-	20	μV _{rms}
0-1 kHz	Gain=20		-	-	2.5	μV _{rms}
	Gain=1		-	-	50	μV _{rms}
0-2 kHz	Gain=20		-	-	3.75	μV _{rms}
	Gain=1		-	-	75	μV _{rms}
Reference Output						
Output Voltage	REFOUT	1.15	1.2	1.25	V	
Temperature Coefficient		-	25	50	ppm/°C	
Load Regulation (Output Current 1 μA Source or Sink)	ΔV _R	-	6	10	mV	
Power Supply Rejection	PSRR	60	-	-	dB	
Reference Input						
Input Voltage Range	VREF+	1.15	1.2	1.25	V	
Input Capacitance		-	-	10	pF	
Input CVF Current		-	-	1	μA	

ANALOG CHARACTERISTICS (continued)

Parameter	Symbol	Min	Typ	Max	Unit	
Power Supplies						
Power Supply Currents Typical VA+ = VD+ = +3 V; VA- = -2 V	I _{A+}	PSCA	-	4.0	5.3	mA
	I _{D+} with CPD	PSCD	-	5.0	6.3	mA
	I _{D+} without CPD	PSCD	-	1.0	1.5	mA
Power Consumption (Note 2)	With CPD	PC	-	27	35	mW
	Without CPD	PC	-	23	31	mW
Power Supply Rejection 50, 60 Hz (Note 3)	(DC)	PSRR	50	-	-	dB
	Voltage Channel	PSRR	50	65	-	dB
	Current Channel	PSRR	60	90	-	dB

- Notes:
- Specifications for Gain = 20 apply only to Current Channels. Voltage Channels are fixed to Gain = 1
 - All outputs unloaded. All inputs CMOS level.
 - Definition for PSRR: VREFIN tied to VREFOUT, VA+ = VD+ = 3 V, AGND = DGND = 0 V, VA- = -2 V (using charge-pump circuit with CPD). In addition, a 106.07 mV rms (60 Hz) sinewave is imposed onto the VA+ and VD+ pins. The “+” and “-” input pins of both input channels are shorted to VA-. 2048 instantaneous digital output data words are collected for the channel under test. The rms value of the digital sinusoidal output signal is calculated, and this rms value is converted into the rms value of the sinusoidal voltage (measured in mV) that would need to be applied at the channel’s inputs, in order to cause the same digital sinusoidal output. This voltage is then defined as V_{eq}. PSRR is then (in dB):

$$PSRR = 20 \cdot \log \left\{ \frac{106.07}{V_{eq}} \right\}$$

DIGITAL CHARACTERISTICS (See Note 4)

- Min/Max characteristics and specifications are guaranteed over all Operating Conditions.
- Typical characteristics and specifications are measured at nominal supply voltages and TA = 25 °C.
- VA+ = VD+ = 3V ±10%; VA- = -2 V ±10%; AGND = DGND = 0 V. All voltages with respect to 0 V.
- XIN = 4.096 MHz

Parameter	Symbol	Min	Typ	Max	Unit
Master Clock Characteristics					
Master Clock Frequency	XIN	3	4.096	5	MHz
Master Clock Duty Cycle		40	-	60	%
Filter Characteristics					
High Rate Filter Output Word Rate	OWRS = 0	OWR	-	XIN/2048	Hz
	OWRS = 1	OWR	-	XIN/1024	Hz
Input/Output Characteristics					
High-Level Input Voltage	V _{IH}	0.6 VD+	-	VD+	V
Low-Level Input Voltage	V _{IL}	0.0	-	0.8	V
High-Level Output Voltage	I _{out} = -5.0 mA	V _{OH}	(VD+) - 1.0	-	V
Low-Level Output Voltage	I _{out} = 5.0 mA	V _{OL}	-	0.4	V
Input Leakage Current (Note 5)	I _{in}	-	±1	±10	µA
3-State Leakage Current	I _{OZ}	-	-	±10	µA
Digital Output Pin Capacitance	C _{out}	-	9	-	pF

- Notes:
- All measurements performed under static conditions.
 - For OWRS and GAIN pins, input leakage current is 30 µA (Max).

SWITCHING CHARACTERISTICS

- Min/Max characteristics and specifications are guaranteed over all Operating Conditions.
- Typical characteristics and specifications are measured at nominal supply voltages and $T_A = 25\text{ }^\circ\text{C}$.
- $V_{A+} = V_{D+} = 3\text{ V} \pm 10\%$; $V_{A-} = -2\text{ V} \pm 10\%$; $AGND = DGND = 0\text{ V}$. All voltages with respect to 0 V.
- Logic Levels: Logic 0 = 0 V, Logic 1 = V_{D+}

Parameter		Symbol	Min	Typ	Max	Unit
Rise Times (Note 6)	Any Digital Input (except XIN)	t_{rise}	-	-	1.0	μs
	XIN only		-	-	10	ns
	Any Digital Output		-	50	-	ns
Fall Times (Note 6)	Any Digital Input (except XIN)	t_{fall}	-	-	1.0	μs
	XIN only		-	-	10	ns
	Any Digital Output		-	50	-	ns
Serial Port Timing						
Serial Clock Frequency (Note 7)	OWRS = "0"	SCLK	-	500	-	kHz
	OWRS = "1"	SCLK	-	1000	-	kHz
Serial Clock (Note 7 and 8)	Pulse Width High	t_1	-	0.5	-	SCLK
	Pulse Width Low	t_2	-	0.5	-	SCLK
SCLK falling to New Data Bit		t_3	-	-	50	ns
FSO Falling to SCLK Rising Delay	(Note 7 & 8)	t_4	-	0.5	-	SCLK
FSO Pulse Width	(Note 7 & 8)	t_5	-	1	-	SCLK
SE Rising to Output Enabled	(Note 9)	t_6	-	-	50	ns
SE Falling to Output in Tri-state		t_7	-	-	50	ns

- Notes:
6. Specified using 10% and 90% points on wave-form of interest. Output loaded with 50 pF.
 7. Device parameters are specified with $XIN = 4.096\text{ MHz}$.
 8. Device parameters are specified with $OWRS = 1$.
 9. After SE is asserted, the states of SDO and SCLK are FSO is undefined.

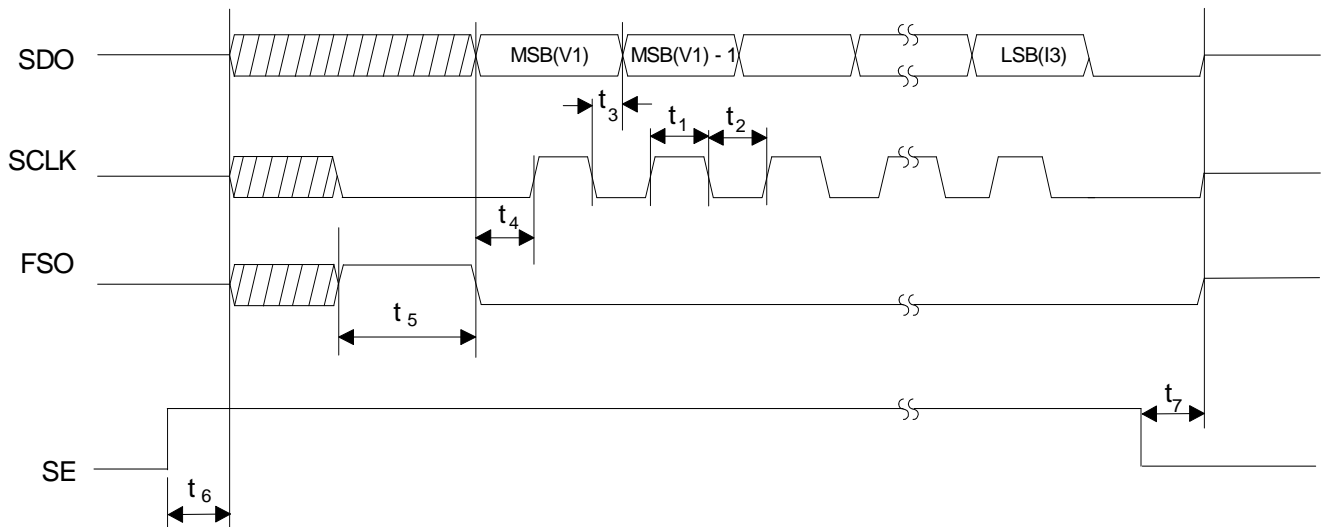

Figure 1. Serial Port Timing

ABSOLUTE MAXIMUM RATINGS

WARNING: Operation at or beyond these limits may result in permanent damage to the device.
Normal operation is not guaranteed at these extremes.

Parameter		Symbol	Min	Typ	Max	Unit
DC Power Supplies	Positive Digital	VD+	-0.3	-	+3.5	V
	Positive Analog	VA+	-0.3	-	+3.5	V
	Negative Analog	VA-	-2.5	-	-0.3	V
Input Current, Any Pin Except Supplies	(Note 10 and 11)	I _{IN}	-	-	±10	mA
Output Current		I _{OUT}	-	-	±25	mA
Power Dissipation	(Note 12)	PDN	-	-	500	mW
Analog Input Voltage	All Analog Pins	V _{INA}	(VA-) - 0.3	-	(VA+) + 0.3	V
Digital Input Voltage	All Digital Pins	V _{IND}	-0.3	-	(VD+) + 0.3	V
Ambient Operating Temperature		T _A	-40	-	85	°C
Storage Temperature		T _{stg}	-65	-	150	°C

- Notes: 10. Applies to all pins including continuous over-voltage conditions at the analog input (AIN) pins.
 11. Transient current of up to 100 mA will not cause SCR latch-up. Maximum input current for a power supply pin is ±50 mA.
 12. Total power dissipation, including all input currents and output currents.

3. THEORY OF OPERATION

The CS5451A is a six-channel analog-to-digital converter (ADC) followed by a serial interface that allows communication with a target device. The analog inputs are structured for 3-phase power meter applications, with three dedicated voltage and current channels. Figure 2 illustrates the CS5451A typical inputs and power supply connections.

The voltage-sensing element introduces a voltage waveform on the voltage channel inputs $VIN(1-3)\pm$ and is subject to a fixed 1x gain amplifier. A fourth-order delta-sigma modulator samples the amplified signal for digitization.

Simultaneously, the current-sensing element introduces a voltage waveform on the current channel input

$IIN(1-3)\pm$ and is subject to two selectable gains of the programmable gain amplifier (PGA). The amplified signal is sampled by a fourth-order delta-sigma modulator for digitization. Both converters sample at a rate of $XIN/8$, the over-sampling provides a wide dynamic range and simplified anti-alias filter design.

The decimating digital filters on all channels are $Sinc^3$ filters. The single bit data is passed to the low-pass decimation filter and output at a fixed word rate. The decimation rate is selectable for two output word rates.

The 16-bit output word is then transmitted via a master serial data port. The six-channel data is multiplexed on the serial data output and is preceded by a frame sync signal.

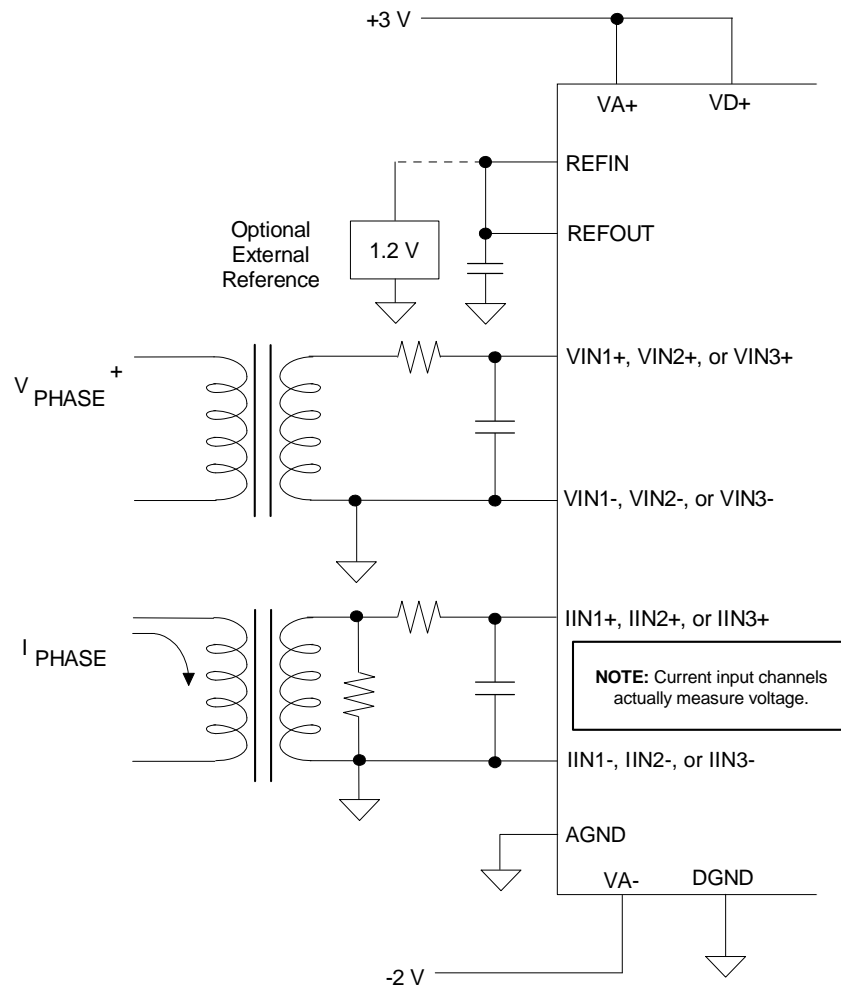

Figure 2. Typical Connection Diagram

4. FUNCTIONAL DESCRIPTION

4.1 Analog Inputs

The CS5451A is equipped with six fully differential input channels. The inputs $VIN(1-3)\pm$ and $IIN(1-3)\pm$ are designated as the voltage and current channel inputs, respectively. The full-scale differential input voltage for the current and voltage channel is $\pm 800\text{ mV}_P$ (gain = 1x).

4.1.1 Voltage Channel

The output of the line voltage resistive divider or transformer is connected to the $VIN(1-3)+$ and $VIN(1-3)-$ input pins of the CS5451A. The voltage channels are equipped with a 1x fixed gain amplifier. The full-scale signal level that can be applied to the voltage channel is $\pm 800\text{ mV}$. If the input signal is a sine wave the maximum RMS voltage is:

$$\frac{800\text{ mV}_P}{\sqrt{2}} \cong 565.69\text{ mV}_{RMS}$$

which is approximately 70.7% of maximum peak voltage.

4.1.2 Current Channel

The output of the current sense resistor or transformer is connected to the $IIN(1-3)+$ and $IIN(1-3)-$ input pins of the CS5451A. To accommodate different current-sensing devices the current channels incorporate a programmable gain amplifier (PGA) that can be set to one of two input ranges. Input pin GAIN (see Table 1) define the PGA's two gain selections and corresponding maximum input signal level.

GAIN	Maximum Input Range	
0	$\pm 40\text{ mV}$	20x
1	$\pm 800\text{ mV}$	1x

Table 1. Current Channel PGA Setting

4.2 Digital Filters

The decimating digital filter samples the modulator bit stream at $XIN/8$ and produces a fixed output word rate. The digital filters are implemented as sinc^3 filters with the following transfer function:

$$H(z) = \left(\frac{1 - z^{-DR}}{1 - z^{-1}} \right)^3$$

The decimation rate is determined by the exponent DR (see Table 2).

The output word rate (OWR) is selected by the OWRS pin and defined by Table 2.

OWRS	DR	Output Word Rate
0	256	$XIN/2048$
1	128	$XIN/1024$

Table 2. Decimation Filter OWR

4.3 Performing Measurements

The ADC outputs are transferred in 16-bit, signed (two's complement) data formats. Table 3 defines the relationship between the differential voltage applied to any one of the input channels and the corresponding output code. Note that for the current channels, the state of the GAIN input pin is assumed to driven low such that the PGA gain on the current channels is 1x. If the PGA gain of the current channels is set to 20x, a +40 mV voltage is applied to any pair of $IIN(1-3)\pm$ pins would cause an output code of 32767.

Differential Input Voltage (mV)	Output Code (hexadecimal)	Output Code (decimal)
+800	7FFF	32767
0.0122 to 0.0366	0001	1
-0.0122 to 0.0122	0000	0
-0.0122 to -0.0366	FFFF	-1
-800	8000	-32768

Notes: Assume PGA gain is set to 1x.

Table 3. Differential Input Voltage vs. Output Code

4.4 Serial Interface

The CS5451A communicates with a target device via a master serial data output port. Output data is provided on the SDO output synchronous with the SCLK output. A third output, FSO, is a framing signal used to signal the start of output data. These three outputs will be driven as long as the SE (serial enable) input is held high. Otherwise, these outputs will be high-impedance.

Data out (SDO) changes as a result of SCLK falling, and always outputs valid data on the rising edge of SCLK. When data is being transferred the SCLK frequency is $XIN/8$ when OWRS is low or $XIN/4$ when OWRS is high.

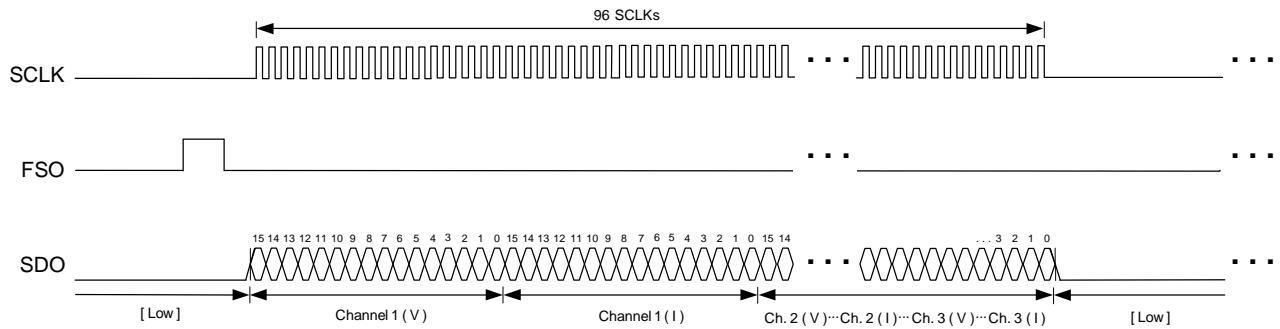

Figure 3. One Data Frame

When data is not being transferred SCLK is held low. (see Figure 3.)

The framing signal (FSO) output is normally low. FSO goes high, with a pulse width equal to one SCLK period, when the instantaneous voltage and current data samples are about to be transmitted out of the serial interface (after each A/D conversion cycle). SCLK is not active during FSO high.

For 96 SCLK periods after FSO falls, SCLK is active and SDO provides valid output. Six channels of 16-bit data are output, MSB first. Figure 4 illustrates how the voltage and current measurements are output for the three phases. SCLK will then be held low until the next sample period.

4.5 System Initialization

A hardware reset is initiated when the $\overline{\text{RESET}}$ pin is forced low with a minimum pulse width of 50 ns. When

$\overline{\text{RESET}}$ is activated, all internal registers are set to a default state.

Upon powering up, the $\overline{\text{RESET}}$ pin must be held low (active) until after the power stabilizes.

4.6 Voltage Reference

The CS5451A is specified for operation with a +1.2 V reference between the VREFIN and AGND pins. The converter includes an internal 1.2 V reference that can be used by connecting the VREFOUT pin to the VREFIN pin of the device. The VREFIN can be used to connect external filtering and/or references.

4.7 Power Supply

The low, stable analog power consumption and superior supply rejection of the CS5451A allow for the use of a simple charge-pump negative supply generator. The use of a negative supply alleviates the need for level

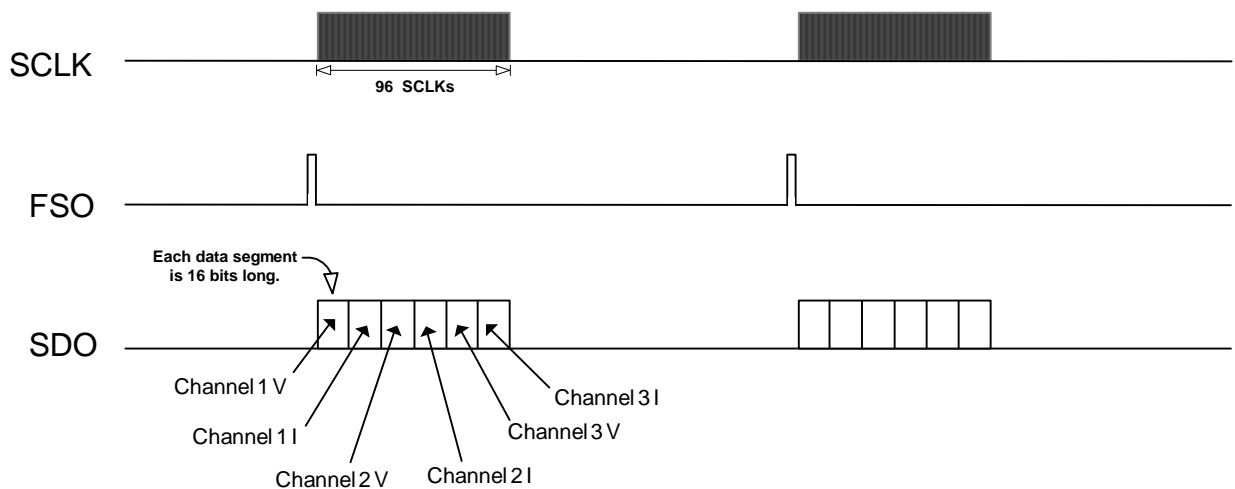

Figure 4. Serial Port Data Transfer

shifting of the analog inputs. The CPD pin and capacitor C1 provide the necessary analog supply current as shown in Figure 5. The Schottky diodes D1 and D2 are chosen for their low forward voltages and high-speed capabilities. The capacitor C2 provides the required charge storage and bypassing of the negative supply. The CPD output signal provides the charge pump driver signal. The frequency of the charge pump driver signal is synchronous to XIN. The nominal average frequency is 1 MHz. The level on the VA- pin is fed back internally so that the CPD output will regulate the VA- level to -2/3 of VA+ level.

The value of capacitor C1 (see Figure 5) is dependent on the XIN clock frequency. The 39 nF value for C1 was selected for a XIN clock frequency equal to 4.096 MHz. For more information about the operation of this type of charge pump circuit, the reader can refer to Cirrus Logic, Inc.'s application note *AN152: Using the*

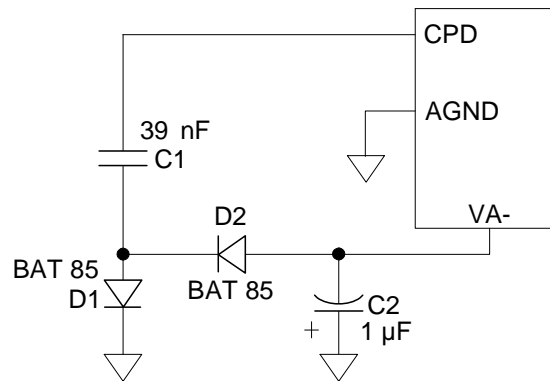
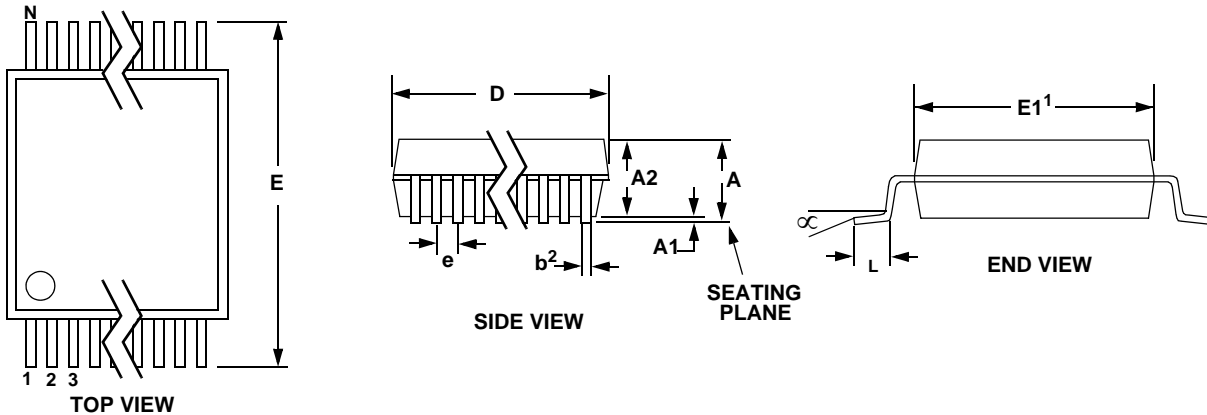

Figure 5. Generating VA- with a Charge Pump

CS5521/24/28, and CS5525/26 Charge Pump Drive for External Loads.

5. PACKAGE DIMENSIONS
28L SSOP PACKAGE DRAWING

DIM	INCHES			MILLIMETERS			NOTE
	MIN	NOM	MAX	MIN	NOM	MAX	
A	--	--	0.084	--	--	2.13	
A1	0.002	0.006	0.010	0.05	0.13	0.25	
A2	0.064	0.069	0.074	1.62	1.75	1.88	
b	0.009	--	0.015	0.22	--	0.38	2,3
D	0.390	0.4015	0.413	9.90	10.20	10.50	1
E	0.291	0.307	0.323	7.40	7.80	8.20	
E1	0.197	0.209	0.220	5.00	5.30	5.60	1
e	0.022	0.026	0.030	0.55	0.65	0.75	
L	0.025	0.0354	0.041	0.63	0.90	1.03	
α	0°	4°	8°	0°	4°	8°	

JEDEC #: MO-150

- Notes:
1. "D" and "E1" are reference datums and do not include mold flash or protrusions, but do include mold mismatch and are measured at the parting line, mold flash or protrusions shall not exceed 0.20 mm per side.
 2. Dimension "b" does not include dambar protrusion/intrusion. Allowable dambar protrusion shall be 0.13 mm total in excess of "b" dimension at maximum material condition. Dambar intrusion shall not reduce dimension "b" by more than 0.07 mm at least material condition.
 3. These dimensions apply to the flat section of the lead between 0.10 and 0.25 mm from lead tips.

6. ORDERING INFORMATION

Model	Temperature	Package
CS5451A-ISZ (lead free)	-40 to +85 °C	28-pin SSOP

7. ENVIRONMENTAL, MANUFACTURING, & HANDLING INFORMATION

Model Number	Peak Reflow Temp	MSL Rating*	Max Floor Life
CS5451A-ISZ (lead free)	260 °C	3	7 Days

* MSL (Moisture Sensitivity Level) as specified by IPC/JEDEC J-STD-020.

8. REVISION HISTORY

Revision	Date	Changes
A1	JUL 2003	Initial Release
PP1	OCT 2003	Initial release for Preliminary Product Information
F1	FEB 2005	Update electrical specifications w/ most-current characterization data.
F2	AUG 2005	Update electrical specifications w/ most-current characterization data. Added MSL data.
F3	FEB 2010	Corrected typical input sampling rate from XIN/4 to XIN/8 (Hz).
F4	APR 2011	Removed lead-containing (Pb) device ordering information.

Contacting Cirrus Logic Support

For all product questions and inquiries contact a Cirrus Logic Sales Representative.

To find the one nearest to you go to www.cirrus.com

IMPORTANT NOTICE

Cirrus Logic, Inc. and its subsidiaries ("Cirrus") believe that the information contained in this document is accurate and reliable. However, the information is subject to change without notice and is provided "AS IS" without warranty of any kind (express or implied). Customers are advised to obtain the latest version of relevant information to verify, before placing orders, that information being relied on is current and complete. All products are sold subject to the terms and conditions of sale supplied at the time of order acknowledgment, including those pertaining to warranty, indemnification, and limitation of liability. No responsibility is assumed by Cirrus for the use of this information, including use of this information as the basis for manufacture or sale of any items, or for infringement of patents or other rights of third parties. This document is the property of Cirrus and by furnishing this information, Cirrus grants no license, express or implied under any patents, mask work rights, copyrights, trademarks, trade secrets or other intellectual property rights. Cirrus owns the copyrights associated with the information contained herein and gives consent for copies to be made of the information only for use within your organization with respect to Cirrus integrated circuits or other products of Cirrus. This consent does not extend to other copying such as copying for general distribution, advertising or promotional purposes, or for creating any work for resale.

CERTAIN APPLICATIONS USING SEMICONDUCTOR PRODUCTS MAY INVOLVE POTENTIAL RISKS OF DEATH, PERSONAL INJURY, OR SEVERE PROPERTY OR ENVIRONMENTAL DAMAGE ("CRITICAL APPLICATIONS"). CIRRUS PRODUCTS ARE NOT DESIGNED, AUTHORIZED OR WARRANTED FOR USE IN PRODUCTS SURGICALLY IMPLANTED INTO THE BODY, AUTOMOTIVE SAFETY OR SECURITY DEVICES, LIFE SUPPORT PRODUCTS OR OTHER CRITICAL APPLICATIONS. INCLUSION OF CIRRUS PRODUCTS IN SUCH APPLICATIONS IS UNDERSTOOD TO BE FULLY AT THE CUSTOMER'S RISK AND CIRRUS DISCLAIMS AND MAKES NO WARRANTY, EXPRESS, STATUTORY OR IMPLIED, INCLUDING THE IMPLIED WARRANTIES OF MERCHANTABILITY AND FITNESS FOR PARTICULAR PURPOSE, WITH REGARD TO ANY CIRRUS PRODUCT THAT IS USED IN SUCH A MANNER. IF THE CUSTOMER OR CUSTOMER'S CUSTOMER USES OR PERMITS THE USE OF CIRRUS PRODUCTS IN CRITICAL APPLICATIONS, CUSTOMER AGREES, BY SUCH USE, TO FULLY INDEMNIFY CIRRUS, ITS OFFICERS, DIRECTORS, EMPLOYEES, DISTRIBUTORS AND OTHER AGENTS FROM ANY AND ALL LIABILITY, INCLUDING ATTORNEYS' FEES AND COSTS, THAT MAY RESULT FROM OR ARISE IN CONNECTION WITH THESE USES.

Cirrus Logic, Cirrus, and the Cirrus Logic logo designs are trademarks of Cirrus Logic, Inc. All other brand and product names in this document may be trademarks or service marks of their respective owners.